

THE SCIENCE OF CLEAR TONE TECHNOLOGY

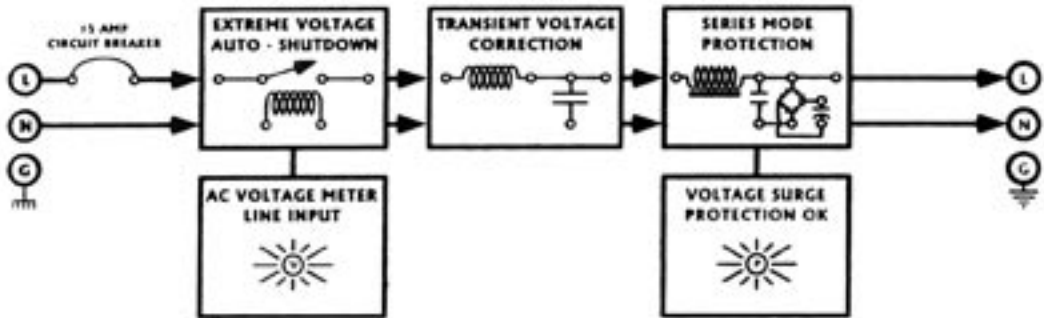

**FURMAN**  
**POWER FACTOR PRO**  
**OWNER'S MANUAL**

## FEATURES

---

- *Clear Tone Technology provides Power Factor correction with 45 amps peak current reservoir*
- *SMP (Series Mode Protection) with extreme voltage shutdown*
- *LiFT (Linear Filtering Technology) with zero ground contamination*
- *Four rear panel outlets*
- *12 amp rating, with circuit breaker*
- *Three year limited warranty*
- *Front panel meter to display incoming line voltage ranging from 90 to 128 volts*

## INTRODUCTION

---

Congratulations on your purchase of a Furman Power Factor Pro. The Power Factor Pro features Furman's revolutionary Clear Tone Technology, Series Mode Protection (SMP) circuit, as well as our exclusive Linear Filtering Technology (LiFT). Together these technologies comprise what is, without question, the world's first comprehensive instrument amplifier AC power conditioner.

Today's AC power is contaminated. Whether you play in a stadium, bar, or rehearsal space, they all have one thing in common: the AC power is supplied from your local utility. What's worse is that the "power factor" supplied from your building's AC outlet is typically poor, thanks to increasingly over

taxed power lines and raised line impedance.

In fact, the quality of AC power has been so poor for so long, most musicians have no idea how great their amplifiers could really sound. When the AC power factor is poor, amplifiers sound muddy because their power supplies can't deliver when pushed. The scream and cry from a guitar loses bite and harmonics, bass guitars lose their punch and weight, keyboards sound nasally, losing clarity, attack, and extension.

Furman's Power Factor Pro addresses this issue - allowing your amplifier to sound its best while protecting it at the same time.

## DESCRIPTION

---

The Power Factor Pro's "Clear Tone Technology™" actually lowers the AC line impedance supplied by your wall outlet, while storing energy for peak current demands. In fact, there are over 45 amps of instantaneous current reserve in the Power Factor Pro. Additionally, "Linear Filtering Technology™" dramatically lowers AC line noise to unprecedented levels in the critical audio frequency band. What does this mean? Just plug in your current-starved amplifier, crank up the volume, and listen to the dynamics, harmonics, and clarity you've been missing!

Additionally, the Power Factor Pro is the

# POWER FACTOR PRO MANUAL

---

most comprehensive power conditioner ever created for the serious musician. Maintenance-free Series Mode Protection guards your equipment from voltage spikes that can damage your amplifier and change its digital pre-sets.

Furman's SMP features unparalleled clamping voltage. While other designs offer clamping voltages that are well above 330Vpk, Furman's SMP clamps at 188Vpk (133 VAC RMS) even when tested with multiple 6000Vpk - 3000 amp surges! And, our pro level over-voltage auto shutdown circuit assures you will never see your prized amplifier go up in flames due to a sustained voltage overload.

The Power Factor Pro has a generous 12 amp R.M.S. capacity, a convenient 20 segment AC voltmeter, a detachable-locking AC cord, and (4) AC outlets, all contained in a small convenient, floor standing package.

## SAFETY INFORMATION

---

To obtain best results from your Furman Power Factor Pro Power Conditioner, please be sure to read this manual carefully before using.

**WARNING:** To reduce the risk of electrical shock, do not expose this equipment to rain or moisture. Dangerous high voltages

are present inside the enclosure. Do not remove the covers. Refer servicing to qualified personnel only. The lightning flash with an arrowhead symbol, is intended to alert the user to the presence of un-insulated dangerous voltage within the product's enclosure that may be of sufficient magnitude to constitute a risk of electric shock.

## IMPORTANT SAFETY INSTRUCTIONS

(Please read prior to installation)

---

1. Please read and observe all safety and operating instructions before installing your Power Factor Pro unit. Retain these instructions for future reference.
2. Your Power Factor Pro unit should not be used near water – for example, near a bathtub, washbowl, kitchen sink, laundry tub, in a wet basement, near a swimming pool, etc.
3. Do not place your Power Factor Pro unit near heat sources such as radiators, heat registers, stoves, or other appliances that produce heat.
4. The Power Factor Pro should only be connected to a 120 VAC, 60Hz, 15 amp ("E" version - 220 VAC, 10 amp) grounded electrical outlet. Do not defeat the ground or change polarization of the power plug.
5. Pay particular attention to the condition of

the cords and cables at the plugs. To prevent risk of fire or injury, damaged cords and cables should be replaced immediately.

6. Clean your Power Factor Pro unit with a damp cloth only. Do not use solvents or abrasive cleaners. Never pour liquid on or into the unit.

7. Your Power Factor Pro unit should be serviced by qualified service personnel when:

- The power supply cord or the plug has been frayed or cut.
- Objects have fallen or liquid has spilled into the unit.
- The unit has been exposed to rain or other moisture.
- The unit does not appear to operate normally.
- The "Protection OK" indicator is not lit.
- The unit has been dropped, or the enclosure has been *seriously* damaged.

8. Your Power Factor Pro unit requires that a safety ground be present for proper operation.

***Any attempt to operate the unit without a safety ground is considered improper operation and could invalidate the warranty.***

9. Do not attempt to service your Power Factor Pro unit beyond what is described in this manual. All other servicing should be referred to qualified service personnel.

## FEATURES

---

The Power Factor Pro has a master switch for the rear outlets that glows red when the power is on. The circuit breaker is located adjacent to the power switch. It can be quickly and easily reset should the unit be overloaded. The Power Factor Pro also features a detachable 10 foot, 14 gauge heavy-duty power cable.

The Power Factor Pro, offers a 20 segment LED bar-graph meter that displays incoming voltage between 90 and 128 volts in 2-volt increments. The normal range voltages are indicated in green, with moderately and extremely high or low voltages in yellow and red respectively. The voltmeter's accuracy is  $\pm 2$  volts. It can easily be recalibrated, if necessary.

## OPERATION

---

### **Multi-Segment LED Voltmeter:**

This three-color, 20-LED bargraph is an accurate, self checking AC voltmeter that continually measures input voltages. The meter reads from 90 to 128 volts in 2 volt steps (Power Factor Pro E: 180 to 256 volts, in 4 volt steps). The normal range voltages are indicated in green, with moderate and extremely high or low voltages in yellow and red respectively. The voltmeter provides three special flashing patterns to indicate abnormal conditions.

# POWER FACTOR PRO MANUAL

---

- (1) On initial turn on, the voltmeter will scan for smart chip integrity.
- (2) If only the single leftmost (beneath the 90V mark) LED flashes, the input voltage is marginally low.
- (3) If all of the LEDs on the voltmeter flash, the input voltage is marginally high. Power to the Power Factor Pro's outlets will remain unless the incoming voltage rises above the Extreme Voltage Shutdown cutoff voltage (135 - 140 volts).

The Power Factor Pro's voltmeter has a basic accuracy of plus or minus two volts, and extreme cold or heat may cause an additional one volt of error (four volts and two volts for Power Factor Pro E).

*NOTE:* Although the Power Factor correction will more than compensate for peak current demands, the Power Factor Pro does not

compensate for *sustained* high or low line voltage. If you derive power from generators, travel internationally, or are in an area prone to extreme brownouts, you may benefit from the use of one of Furman's AC Line Voltage Regulators.

### **On/Off Rocker Switch:**

This 15 amp capacity power switch is specifically designed to stand up to the enormous high inrush current demands placed by many instrument amplifiers. Additionally, the semi-transparent rocker lights when switched to the "ON" position.

### **Extreme Voltage Shutdown Indicator:**

This LED is normally off. It monitors a hazard unfortunately common in the entertainment industry: wiring faults – for example, accidental connection to 220VAC where 120VAC is expected, or an open neutral from a 208 or 240VAC feed. The Power Factor Pro SMP circuit senses voltages that are so high that operation would be impossible and shuts the

<b>Mains Vltg.</b>	<b>Voltage Status</b>	<b>Voltmeter Reading</b>	<b>Outlets</b>
80-90	Low Marginal	The 90V LED mark flashes	ON
90-104	Low	Meter Reads in Low Red	ON
106-108	Medium Low	Meter Reads in Low Yellow	ON
110-120	Normal	Meter Reads in Green	ON
122-124	Medium High	Meter Reads in High Yellow	ON
126-128	High	Meter Reads in High Red	ON
130-140	High Marginal	All Meter LEDs Flash	ON
Above 140	Extreme (Shutdown)	Meter off—Extreme Voltage LED illuminates	OFF

power down before damage can occur. Upon initially applying power to these units, the Extreme Voltage indicator LED will be lit if the input voltage is above the extreme voltage cutoff, and power will not be applied to the unit's outlets. If the unit has been operating with an acceptable input voltage and then that voltage goes above 135V, it will shut off power to the outlet and the Extreme Voltage LED will light.

**NOTE:** If the mains power is above the high cutoff voltage and has caused the unit to remove power from its outlets, it cannot restore power without the operator manually turning the unit off, then on again. Avoid turning the unit back on without checking the source of the problem first, and perhaps changing the AC source.

## TROUBLE-SHOOTING GUIDE

---

**1.) Symptom:** No power to the AC outlets.

**Possible Cause:** Circuit breaker has tripped due to excessive load.

**Action Needed:** Remove one piece of equipment from the Power Factor Pro unit, and push the square re-set tab into the circuit breaker bezel.

**2.) Symptom:** No power to the AC outlets, "Protection OK" indicator is not lit.

**Possible Cause:** Either the AC outlet that

your Power Factor Pro device is connected to has no AC voltage present, or the unit has been subjected to a *sustained* voltage in excess of 400 volts.

**Action Needed:** Plug the Power Factor Pro unit into an AC receptacle where AC voltage is present. If the problem persists, the protection circuit may be damaged factory service may be required.

**3.) Symptom:** Extreme Voltage indicator lit.

**Possible Cause:** Input voltage is above 135 - 140 volts, causing power to the unit's outlets to be shut down. Additionally, if the voltage is below 85-90 volts at turn on, the unit will not allow AC voltage to reach the outlets.

**Action Needed:** Correct the line voltage. Then turn the unit on. Consider installing a Furman voltage regulator.

## THREE YEAR LIMITED WARRANTY

---

The Power Factor Pro is protected by a limited three year warranty covering defects in materials and workmanship, provided that the registration card is filled out and returned by the customer. Otherwise, a one year warranty applies. Products must have a proof of purchase from a Furman authorized dealer. During this period, Furman will make any necessary repairs without charge for parts or labor. Shipping charges to the factory or repair station must be prepaid by the owner; return shipping charges (via UPS ground) will be paid by Furman. This warranty applies only to

the original owner. Also, it does not apply to repairs done by other than the Furman factory or Authorized Repair Stations.

This warranty may be cancelled by Furman at its sole discretion if the unit has been subjected to physical abuse (including, but not limited to, connection to improper AC or DC voltages), or has been modified in any way without written authorization from Furman. Furman's liability under this warranty is limited to repair or replacement of the defective unit.

Furman will not be responsible for incidental or consequential damages resulting from the use or misuse of its products. EXCEPT AS PROVIDED HEREIN, FURMAN SOUND MAKES NO WARRANTIES, EXPRESSED OR IMPLIED, INCLUDING WARRANTIES OF MERCHANTABILITY AND FITNESS FOR A PARTICULAR PURPOSE. Some states do not allow the exclusion of incidental or consequential damages, so this limitation may not apply to you. This warranty gives you specific legal rights, and you may also have other rights which vary from state to state.

Warranty claims should be accompanied by a copy of the original purchase invoice showing the purchase date (if a Warranty Registration Card was submitted at the time of purchase, this is not necessary). Before returning any equipment for repair, please be sure that it is adequately packed and cushioned against damage in shipment, and that it is insured. Please enclose a note giving your name, address, phone number and a description of the problem.

## SERVICE

---

Before returning any equipment for repair, please be sure that it is adequately packed and cushioned against damage in shipment, and that it is insured. We suggest that you save the original packaging and use it to ship the product for servicing. Also, please enclose a note giving your name, address, phone number and a description of the problem.

NOTE: All equipment being returned for repair must have a Return Authorization (RA) Number. To get an RA Number, please call the Furman Service Department: (707) 763-1010, ext. 121. Please display your RA Number prominently on the front of all packages.



## SPECIFICATIONS

Current rating:

12 amps ("E" versions 7 amps)

Operating Voltage:

90 to 140 VAC ("E" versions 180 to 280 VAC)

Over Voltage Shutdown:

140 VAC *typically* ("E" versions 280 VAC *typically*)

Voltmeter Accuracy:

±2 VAC, calibrated with internal trimpot adjustments

Spike Protection Modes:

Line to neutral, zero ground leakage

Spike Clamping Voltage:

188 Vpk @ 3,000 amps (133 VAC RMS) (tested to  
UL-1449 6,000 Vpk @ 3,000 amps)

Response time:

1 nanosecond

Maximum surge current:

6,500 amps

Noise attenuation:

40 dB @ 10 kHz

40 dB @ 100 kHz

100 dB @ 10 MHz

Linear attenuation curve from 0.05 - 100 ohms line  
impedance

Transient Current Reservoir:

45 amps peak

Mechanical:

Dimensions: 5.25" H (with feet) x 8.125" W x 12.5" D.

Weight: 11 lbs (5 kg).

Construction: Steel chassis, .190" brushed and red  
anodized aluminum side panels; glass epoxy printed  
circuit boards

Power Consumption:

6 watts (resistive)

420 watts (reactive)

Safety Agency Listings:

CE, ETL-C (pending)

# **FURMAN**

Furman Sound, Inc.  
1997 South McDowell Blvd.  
Petaluma, California 94954-6919 USA  
Phone: 707-763-1010  
Fax: 707-763-1310  
Web: [www.furmansound.com](http://www.furmansound.com)  
E-mail: [info@furmansound.com](mailto:info@furmansound.com)